

User Manual

GPS Receiver Engine Board

MTI-1



1. <<Specification>>

Product Features

- SiRF GPS Architecture
- SiRF starII high performance and low power consumption chip set
- Support standard NMEA 0183 protocol
- All-in-view 12-channel parallel processing
- SnapLock 100ms re-acquisition time
- Cold start under 45 seconds, average
- Superior urban canyon performance
- FoliageLock for weak signal tracking
- Optional build-in SuperCap to reserve system data for rapid satellite acquisition.
- Full-duplex RS-232 port for navigation and control messages
- Differential GPS capability through 2nd RS-232 port

System Specification

*** Electrical Characteristics**

<Receiver>

-- Frequency	L1, 1575.42MHz
-- C/A code	1.023MHz chip rate
-- Channels	12
-- Sensitivity	-170dBW

<Accuracy>

-- Position Horizontal	15m 2d RMS (SA off) 10m 2d RMS, WAAS enable(SA off) 1 ~ 5 m, DGPS corrected
-- Velocity	0.1m/sec 95% (SA off),
-- Time	1 microsecond synchronized to GPS time

<Datum>

-- WGS-84

<Acquisition Rate>

-- Reacquisition	0.1 sec., average (recovery time for being interrupted)
-- Hot start	8 sec., average (with ephemeris and almanac valid)
-- Warm start	38 sec., average (with almanac but not ephemeris)
-- Cold start	48 sec., average (neither almanac nor ephemeris)

<Dynamic Condition>

-- Altitude	18,000 meters (60,000 feet) max.
-- Velocity	515 meters/sec. (1000knots) max.

<Power>

-- Voltage supply	3.8Vdc ~ 6.5Vdc
-- Current supply	Continuous mode: 60mA typical Trickle power mode: 25mA typical
-- Backup Power	+2.5V to +3.6V
-- Backup Current	10uA typical

<Serial Port>

- Ports one for GPS, one for DGPS
- Electrical level : TTL level(ET-102), Output voltage level : 0 ~ 3.5v
RS-232 level(ER-102)
- Communication Full duplex asynchronous
- Code type ASCII
- GPS Protocol SiRF binary/NMEA 0183 changeable(Default:NMEA)
- GPS Output Message
 - SiRF binary >> position, velocity, altitude, status and control
 - NMEA 0183 >> GGA, GSA, GSV, RMC (VTG and GLL are optional)

- GPS transfer rate Software command setting
(Default : 4800bps for NMEA)
- DGPS protocol RTCM SC-104, ver 2.00, type 1, 2, and 9

<Time Mark> (1 PPS Pulse)

- Level TTL
- Pulse duration 100ms
- Time reference At the pulse positive edge
- Measurement Aligned to GPS sec., +/- 1us

<Active Antenna Connector>

- MCX ,SMA ,SMB or others OEM specified connector available

* *Environmental Characteristics*

<Temperature>

- Operating -40 deg. C to +80 deg. C
- Storage -40 deg. C to +85 deg. C

*** Physical Characteristics**

<Dimension>

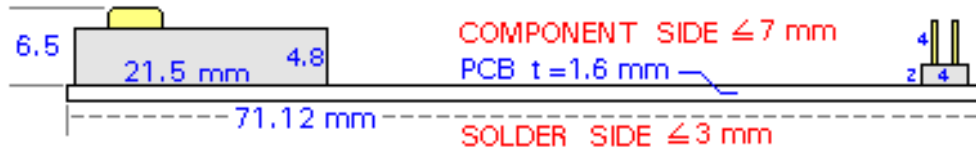

PCB SIDE VIEW

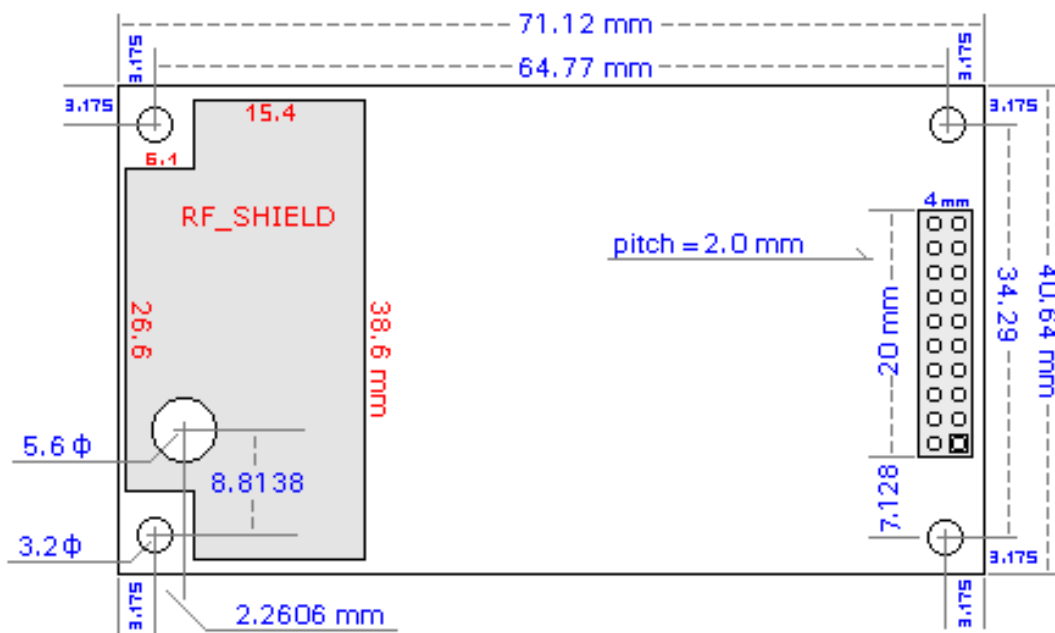

PCB TOP VIEW

Interface Connection

*** Pin-out of the 20-pin interface connector**

Pin Number	Name	Description	Type
1	VANT	Antenna DC Voltage	Input
2	VDC	3.8V~6.5V DC Power Input	Input
3	VBAT	Backup Battery	Input
4	VDC	(Shorted with pin 2)	Input
5	PBRES	Push Button Reset Input (Active Low)	Input
6	RESERVED	(Reserved)	
7	SELECT	Down-load data from RS232 to flash ROM (Reserved)	
8	RESERVED	(Reserved)	
9	RESERVED	(Reserved)	
10	GND	Ground	
11	TXA	Serial Data Output A (GPS Data)	Output
12	RXA	Serial Data Input A (Command)	Input
13	GND	Ground	
14	TXB	Serial Data Output B (No Used)	Output
15	RXB	Serial Data Input B (DGPS Data)	Input
16	GND	Ground	
17	RESERVED	(Reserved)	
18	GND	Ground	
19	TIMEMARK	1PPS Time Mark Output	Output
20	RESERVED	(Reserved)	

Interface description

*** VANT (antenna DC power input):**

DC voltage is for active antenna.

*** VDC (DC power input):**

This is the main DC supply for a 3.8V ~ 6.5V power module board.

*** VBAT (Backup battery):**

This is the battery backup input that powers the SRAM and RTC when main power is removed. Typical current draw is 10uA. Without an external backup battery or Gold-capacitor, the module/engine board will execute a cold start after every turn on. To achieve the faster start-up offered by a hot or warm start, either a battery backup must be connected or a Gold-capacitor should be installed. To maximize battery lifetime, the battery voltage should not exceed the supply voltage and should be between 2.5v and 3.6v.

*** PBRES (Push button reset):**

This pin provides an active-low reset input to the engine board. It causes the engine board to reset and start searching for satellites.

*** SELECT :**

Do not connect.

*** TXA :**

This is the main transmits channel for outputting navigation and measurement data to user's navigation software or user written software.

ET-102: TTL level , 0V ~ 3.5V

ER-102: RS232 level

*** RXA :**

This is the main receive channel for receiving software commands to the engine board from SiRFdemo software or from user written software.

Normally this pin must be kept in high, and if you don't use this pin please connect a resistor to 3.5V to pull high.

*** TXB :**

No function as so far (Do not connect)

*** RXB :**

This is the auxiliary receive channel for inputting differential corrections to the engine board to enable DGPS navigation.

*** Time mark :**

This pin provides one pulse-per-second output from the engine board that is synchronized to GPS time.

*** GND :**

GND provides the ground for the engine board. Connect all grounds.

*** Others :**

Do not connect.

2. SOFTWARE COMMAND

2.1 NMEA Output Command

GGA-Global Positioning System Fixed Data

Table B-2 contains the values for the following example:

```
$GPGGA,161229.487,3723.2475,N,12158.3416,W,1,07,1.0,9.0,M,,,0000*18
```

Table B-2 GGA Data Format

Name	Example	Units	Description
Message ID	\$GPGGA		GGA protocol header
UTC Time	161229.487		hhmmss.sss
Latitude	3723.2475		ddmm.mmmm
N/S Indicator	N		N=north or S=south
Longitude	12158.3416		dddmm.mmmm
E/W Indicator	W		E=east or W=west
Position Fix Indicator	1		See Table B-3
Satellites Used	07		Range 0 to 12
HDOP	1.0		Horizontal Dilution of Precision
MSL Altitude ¹	9.0	meters	
Units	M	meters	
Geoid Separation ¹		meters	
Units	M	meters	
Age of Diff. Corr.		second	Null fields when DGPS is not used
Diff. Ref. Station ID	0000		
Checksum	*18		
<CR><LF>			End of message termination

1. SiRF Technology Inc. does not support geoid corrections. Values are WGS84 ellipsoid heights.

Table B-3 Position Fix Indicator

Value	Description
0	Fix not available or invalid
1	GPS SPS Mode, fix valid
2	Differential GPS, SPS Mode, fix valid
3	GPS PPS Mode, fix valid

GLL-Geographic Position-Latitude/Longitude

Table B-4 contains the values for the following example:

\$GPGLL,3723.2475,N,12158.3416,W,161229.487,A*2C

Table B-4 GLL Data Format

Name	Example	Units	Description
Message ID	\$GPGLL		GLL protocol header
Latitude	3723.2475		ddmm.mmmm
N/S Indicator	n		N=north or S=south
Longitude	12158.3416		dddmm.mmmm
E/W Indicator	W		E=east or W=west
UTC Position	161229.487		hhmmss.sss
Status	A		A=data valid or V=data not valid
Checksum	*2C		
<CR><LF>			End of message termination

GSA-GNSS DOP and Active Satellites

Table B-5 contains the values for the following example:

\$GPGSA,A,3,07,02,26,27,09,04,15,,,,,1.8,1.0,1.5*33

Table B-5 GSA Data Format

Name	Example	Units	Description
Message ID	\$GPGSA		GSA protocol header
Mode1	A		See Table B-6
Mode2	3		See Table B-7
Satellite Used ¹	07		Sv on Channel 1
Satellite Used ¹	02		Sv on Channel 2
.....			
Satellite Used ¹			Sv on Channel 12
PDOP	1.8		Position dilution of Precision
HDOP	1.0		Horizontal dilution of Precision
VDOP	1.5		Vertical dilution of Precision
Checksum	*33		
<CR><LF>			End of message termination

1. Satellite used in solution.

Table B-6 Mode1

Value	Description
M	Manual-forced to operate in 2D or 3D mode
A	2D automatic-allowed to automatically switch 2D/3D

Table B-7 Mode 2

Value	Description
-------	-------------

1	Fix Not Available
2	2D
3	3D

GSV-GNSS Satellites in View

Table B-8 contains the values for the following example:

\$GPGSV,2,1,07,07,79,048,42,02,51,062,43,26,36,256,42,27,27,138,42*71

\$GPGSV,2,2,07,09,23,313,42,04,19,159,41,15,12,041,42*41

Table B-8 GSV Data Format

Name	Example		Description
Message ID	\$GPGSV		GSV protocol header
Number of Messages	2		Range 1 to 3
Message Number	1		Range 1 to 3
Satellites in View	07		
Satellite ID	07		Channel 1(Range 1 to 32)
Elevation	79	degrees	Channel 1(Maximum90)
Azimuth	048	degrees	Channel 1(True, Range 0 to 359)
SNR(C/No)	42	dBHz	Range 0 to 99,null when not tracking
.....		
Satellite ID	27		Channel 4 (Range 1 to 32)
Elevation	27	Degrees	Channel 4(Maximum90)
Azimuth	138	Degrees	Channel 4(True, Range 0 to 359)
SNR(C/No)	42	dBHz	Range 0 to 99,null when not tracking
Checksum	*71		
<CR><LF>			End of message termination

1. Depending on the number of satellites tracked multiple messages of GSV data may be required.

RMC-Recommended Minimum Specific GNSS Data

Table B-10 contains the values for the following example:

\$GPRMC,161229.487,A,3723.2475,N,12158.3416,W,0.13,309.62,120598,,*10

Table B-10 RMC Data Format

Name	Example	Units	Description
Message ID	\$GPRMC		RMC protocol header
UTC Time	161229.487		hhmmss.sss
Status	A		A=data valid or V=data not valid
Latitude	3723.2475		ddmm.mmmm
N/S Indicator	N		N=north or S=south
Longitude	12158.3416		dddmm.mmmm
E/W Indicator	W		E=east or W=west
Speed Over Ground	0.13	knots	
Course Over Ground	309.62	degrees	True
Date	120598		ddmmyy
Magnetic Variation ²		degrees	E=east or W=west
Checksum	*10		
<CR><LF>			End of message termination

SiRF Technology Inc. does not support magnetic declination. All “course over ground” data are geodetic WGS48 directions.

VTG-Course Over Ground and Ground Speed

\$GPVTG,309.62,T,,M,0.13,N,0.2,K*6E

Name	Example	Units	Description
Message ID	\$GPVTG		VTG protocol header
Course	309.62	degrees	Measured heading
Reference	T		True
Course		degrees	Measured heading
Reference	M		Magnetic
Speed	0.13	knots	Measured horizontal speed
Units	N		Knots
Speed	0.2	Km/hr	Measured horizontal speed
Units	K		Kilometers per hour
Checksum	*6E		
<CR><LF>			End of message termination

2.2 NMEA Input Command

A). Set Serial Port ID:100 Set PORTA parameters and protocol

This command message is used to set the protocol(SiRF Binary, NMEA, or USER1) and/or the communication parameters(baud, data bits, stop bits, parity). Generally, this command would be used to switch the module back to SiRF Binary protocol mode where a more extensive command message set is available. For example, to change navigation parameters. When a valid message is received, the parameters will be stored in battery backed SRAM and then the receiver will restart using the saved parameters.

Format:

```
$PSRF100,<protocol>,<baud>,<DataBits>,<StopBits>,<Parity>*CKSUM  
<CR><LF>
```

<protocol>	0=SiRF Binary, 1=NMEA, 4=USER1
<baud>	1200, 2400, 4800, 9600, 19200, 38400
<DataBits>	8,7. Note that SiRF protocol is only valid f8 Data bits
<StopBits>	0,1
<Parity>	0=None, 1=Odd, 2=Even

Example 1: Switch to SiRF Binary protocol at 9600,8,N,1

```
$PSRF100,0,9600,8,1,0*0C<CR><LF>
```

Example 2: Switch to User1 protocol at 38400,8,N,1

```
$PSRF100,4,38400,8,1,0*38<CR><LF>
```

****Checksum Field:** The absolute value calculated by exclusive-OR the 8 data bits of each character in the Sentence, between, but excluding “\$” and “*”. The hexadecimal value of the most significant and least significant 4 bits of the result are converted to two ASCII characters (0-9,A-F) for transmission. The most significant character is transmitted first.

****<CR><LF>** : Hex 0D 0A

B). Navigation Initialization ID : 101 Parameters required for start

This command is used to initialize the module for a warm start, by providing current position (in X, Y, Z coordinates) ,clock offset, and time. This enables the receiver to search for the correct satellite signals at the correct signal parameters. Correct initialization parameters will enable the receiver to acquire signals more quickly, and thus, produce a faster navigational solution.

When a valid Navigation Initialization command is received, the receiver will restart using the input parameters as a basis for satellite selection and acquisition.

Format :

```
$PSRF101,<X>,<Y>,<Z>,<ClkOffset>,<TimeOfWeek>,<WeekNo>,<chnlCount>,<ResetCfg>  
*CKSUM<CR><LF>
```

<X>	X coordinate position INT32
<Y>	Y coordinate position INT32
<Z>	Z coordinate position INT32
<ClkOffset>	Clock offset of the receiver in Hz, Use 0 for last saved value if available. If this is unavailable, a default value of 75000 for GSP1, 95000 for GSP 1/LX will be used. INT32
<TimeOf Week>	GPS Time Of Week UINT32
<WeekNo>	GPS Week Number UINT16 (Week No and Time Of Week calculation from UTC time)
<chnlCount>	Number of channels to use.1-12. If your CPU throughput is not high enough, you could decrease

needed throughput by reducing the number of active channels

UBYTE

<ResetCfg>

bit mask

0x01=Data Valid warm/hotstarts=1

0x02=clear ephemeris warm start=1

0x04=clear memory. Cold start=1

UBYTE

Example: Start using known position and time.

\$ PSRF101,-2686700,-4304200,3851624,96000,497260,921,12,3*7F

C). Set DGPS Port ID:102 Set PORT B parameters for DGPS input

This command is used to control Serial Port B that is an input only serial port used to receive

RTCM differential corrections.

Differential

receivers may output corrections using different

communication parameters.

The default

communication parameters for PORT B are 9600

Baud, 8data bits, 0 stop bits, and no parity.

If a DGPS

receiver is used which has different communication parameters, use this command to

allow the receiver to correctly decode the data. When a valid message is received, the

parameters will be stored in battery backed SRAM and then the receiver will restart using

the saved parameters.

Format:

\$ PSRF102,<Baud>,<DataBits>,<StopBits>,<Parity>*CKSUM<CR><LF>

<baud> 1200,2400,4800,9600,19200,38400

<DataBits> 8

<StopBits> 0,1

<Parity> 0=None,Odd=1,Even=2

Example: Set DGPS Port to be 9600,8,N,1

\$ PSRF102,9600,8,1.0*12

D). Query/Rate Control ID:103 Query standard NMEA message and/or set output rate

This command is used to control the output of standard NMEA message GGA, GLL, GSA, GSV

RMC, VTG. Using this command message, standard NMEA message may be polled once, or setup for periodic output. Checksums may also be enabled or disabled depending on the needs of the receiving program. NMEA message settings are saved in battery backed memory for each entry when the message is accepted.

Format:

```
$ PSRF103,<msg>,<mode>,<rate>,<cksumEnable>*CKSUM<CR><LF>
```

<msg>	0=GGA,1=GLL,2=GSA,3=GSV,4=RMC,5=VTG
<mode>	0=SetRate,1=Query
<rate>	Output every <rate>seconds, off=0,max=255
<cksumEnable>	0=disable Checksum,1=Enable checksum for specified message

Example 1: Query the GGA message with checksum enabled

```
$ PSRF103,00,01,00,01*25
```

Example 2: Enable VTG message for a 1Hz constant output with checksum enabled

```
$ PSRF103,05,00,01,01*20
```

Example 3: Disable VTG message

```
$ PSRF103,05,00,00,01*21
```

E). LLA Navigation Initialization start using Lat/Lon/Alt

ID:104 Parameters required to

This command is used to initialize the module for a warm start, by providing current position (in Latitude, Longitude, Altitude coordinates), clock offset, and time. This enables the receiver to search for the correct satellite signals at the correct signal parameters. Correct initialization parameters will enable the receiver to acquire signals more quickly, and thus, will produce a faster navigational solution.

When a valid LLANavigationInitialization command is received, the receiver will restart using the input parameters as a basis for satellite selection and acquisition.

Format:

```
$PSRF104,<Lat>,<Lon>,<Alt>,<ClkOffset>,<TimeOfWeek>,<WeekNo>,<ChannelCount>,<ResetCfg>*CKSUM<CR><LF>
```

<Lat>	Latitude position, assumed positive north of equator and negative south of equator float, possibly signed
<Lon>	Longitude position, it is assumed positive east of Greenwich and negative west of Greenwich Float, possibly signed
<Alt>	Altitude position float, possibly signed
<ClkOffset>	Clock Offset of the receiver in Hz, use 0 for last saved value if available. If this is unavailable, a default value of 75000 for GSP1, 95000 for GSP1/LX will be used. INT32
<TimeOfWeek>	GPS Time Of Week UINT32
<WeekNo>	GPS Week Number UINT16
<ChannelCount>	Number of channels to use. 1-12 UBYTE
<ResetCfg>	bit mask 0x01=Data Valid warm/hot starts=1

0×02=clear ephemeris warm start=1

0×04=clear memory. Cold start=1

UBYTE

Example: Start using known position and time.

\$ PSRF104,37.3875111,-121.97232,0,96000,237759,922,12,3*37

**F). Development Data On/Off ID:105 Switch Development Data
Messages On/Off**

Use this command to enable development debug information if you are having trouble getting commands accepted. Invalid commands will generate debug information that should enable the user to determine the source of the command rejection. Common reasons for input command rejection are invalid checksum or parameter out of specified range. This setting is not preserved across a module reset.

Format: \$ PSRF105,<debug>*CKSUM<CR><LF>

<debug> 0=Off,1=On

Example: Debug On \$ PSRF105,1*3E

Example: Debug Off \$ PSRF105,0*3F

Stars Navigation Tech Ltd.

7Fl.-1, No. 152, Sec. 1, Jungshan Rd., Shulin City, Taipei, Taiwan 238, R.O.C.

TEL: +886 2 2681547 FAX: +886 2 2681 5469 E-mail: sales@starsnav.com

URL: www.starsnav.com